

CUSTOMER: _____

Guangzhou Shenghe Electronic Technology Co., Ltd.

SPECIFICATION FOR APPROVAL

Product Description: Aluminum Electrolytic Capacitors

Customer No.:

Specification: HP 6800 μ F/63V 30X50 82VF

Date : 9th, May, 2022

Environmental Certification: ROHS

SHDR[®]



Confirmation from Manufacturer

Drafted by	Verified by	Approved by
姚海洋		李艳林

Confirmation from User

	Verified by	Approved by
		

Manufacturer: Guangzhou Shenghe Electronic Technology Co., Ltd.

Address: No. 232 west Huifu road, Yuexiu district, Guangzhou

Contact: 0086 15920403979

keven@shdrcap.com

<http://www.shdrcap.com/>

After signing, please kindly return one copy. Thanks.

SHDR® Application Notes

When you use aluminum electrolytic capacitors ,remember the following:

1. Polarity

Regular aluminum electrolytic capacitors has polarity

Reverse voltage causes short circuit breakage of the capacitor or leakage of electrolyte .Where the polarity in a circuit sometimes reversed or unknown ,a bi-polar capacitor should be used.

2. Overvoltage

Do not apply overvoltage continuously.

When overvoltage is applied to the capacitor ,leakage current increase drastically.

Applied working voltage to capacitors should not exceed the rated working voltage of capacitor.

3. Operating temperature and life

Do not use the capacitor over the max operating temperature.

Life time of the capacitor depends on the temperature.

Generally ,life time is doubled by decreasing each temperature 10°C

Use temperature as low as possible.

4. Vent

It is recommended at least 3mm of space around the vent.

If such space is not provided ,the vent will not operate completely.

5. Ripple current

Do not apply a ripple current exceeding the rated maximum ripple current.

Applying too much ripple current to the capacitor causes great heat generation ,invites deterioration of properties of causes breakage.

Please consult factory if ripple current exceeds the specified limit.

6. Charge and discharging

Frequent and quick charge/discharge generates heat inside the capacitor ,causing increase of leakage current ,decrease of capacitor ,or breakage occasionally.

Consult us for assistance in this application.

7. Storage

When the capacitor is stored for a long time without applying voltage ,leakage current tends to increase.

This returns to normal by applying the rated voltage to the capacitor before use.

It is recommended to apply D.C .working voltage to the capacitor for 30 minutes through 1kΩ of protective series resistor ,if it is stored for more than 6 mouths .

The capacitor should be stored at a normal temperature and humidity .

8. Soldering

Improper soldering may shrink or break the insulating sleeve add/or damage the internal element as terminals and Lead wires conduct heat into the capacitor.

Avoid too high a soldering temperature and/or too long a soldering time.

9. Mechanical stress on the lead wire and the terminal

Do not apply excessive force to the lead wire and the terminal.

Do not move the capacitor after soldering to the PC board ,not carry the PC board by picking up the capacitor .For their strength ,refer to JIS C-5141 and C-5102.

10. Cleaning of boards after soldering

If the capacitor is cleaned in halogenated solvent for organic removing solder flux solvent ,the solvent may penetrate into inside of capacitor, and may generate corrosion.

11. Sleeve material

The standard sleeve material is polyvinyl-chloride.

If exposed to xylene ,toluene ,etc ,and then subjected to high heat ,the sleeve may crack .This sleeve is not insulating material.

12 .Micon' s Products meet or exceed quality standards specified by JIS-C5141W and with the reliability requirements refer to JIS-C-5102.

13 .None of ozone depleting chemicals(ODC) under the Montreal Protocol is manufacturing process of Shen Zhen Moonlight Electronic Industrial CO.,Ltd.

SHDR® HP Series

HP Series Snap-in Type 105°C

Features

- ◆ Highly reliable capacitors that withstand ripple current.
- ◆ Terminal spacing fixed at 10 mm for printed circuit board plug in.
- ◆ Aluminum case designed explosion-proof vent.
- ◆ Best for switching power supplies.

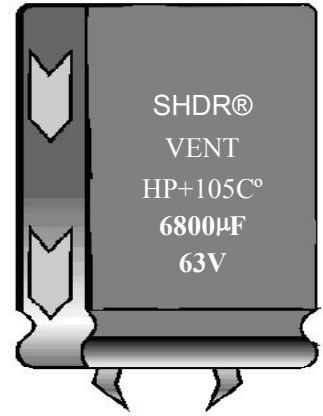

Specifications

Item	Performance Characteristics													
Operating Temperature Range	-40to+105°C	-25to+105°C												
Rated Voltage Range	10to100VDC	160to450VDC												
Capacitance Range	330to68000 µF	33to2200 µF												
Capacitance Tolerance	±20% (100Hzor120Hz, +20°C)													
Leakage Current (+20°C)	I ≤ 0.02CV After 5 minutes, whichever is greater measured with rated working voltage applied													
Dissipation Factor (tg δ)	µF \ WVDC	10~16	25~35	50~63	80~100	160~250	315~450							
	47~390	--	--	--	15	15	20							
	470~3900	25	20	20	20	15	20							
	4700~8200	35	30	30	25									
	10000~22000	40	35	30	--	--	--							
	27000~47000	45	40	35	--	--	--							
	56000~68000	50	45	--	--	--	--							
	(100Hzor120Hz, +20°C)													
Low Temperature Characteristics (120Hz)	Impedance ratio , 120Hz													
	电压(V)	10	16	25	35	50	63	80	100	160	200	250	400	450
	Z - 25°C / Z+20°C	5	5	4	4	4	4	4	4	4	4	4	4	4
Z - 40°C / Z+20°C	15	15	15	12	12	12	12	--	--	--	--	--	--	
Load Life	Test conditions Duration time: 2000 hours Ambient temperature: +105°C Applied voltage : Rated Working Voltage (VDC) After test requirements: Resumed 16 hours at normal temperature Capacitance change: ≤ ±20% of the initial measured value Dissipation Factor: ≤ 200% of the initial specified value Leakage Current: ≤ The initial specified value													
Shelf Life	Test conditions Duration time: 1000 hours Ambient temperature: +105°C Applied voltage : None After test requirements: Resumed 16 hours at normal temperature Same limits as Load Life													

Diagram of Dimension (Unit:mm)

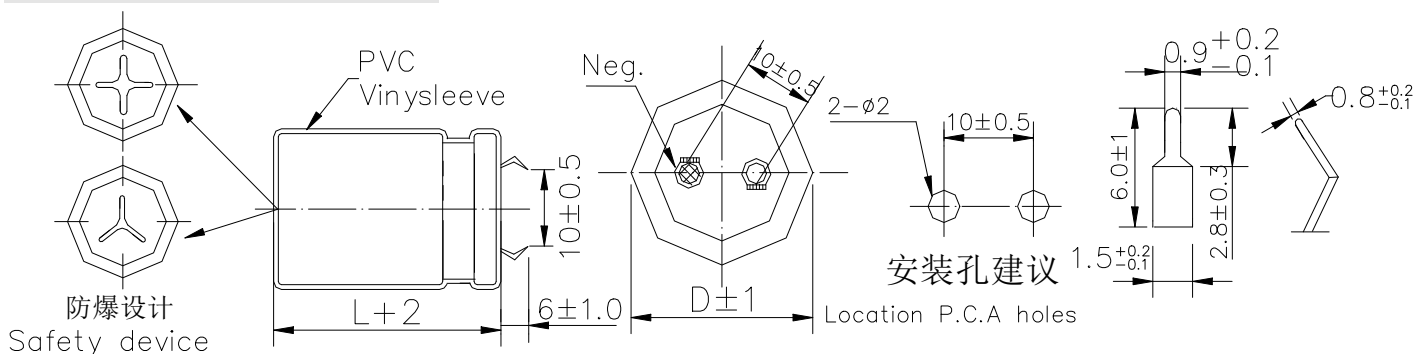

Guangzhou Shenghe Electronic Technology Co., Ltd

Aluminum Electrolytic Capacitors Sample Test Report

Test Date: 2022-05-09

Customer		Series	HP	Sleeve Color	Black & Silver
Sample Qty	10 pcs	Specification	6800 μ F/63V	Part Number	
Test Qty	10 pcs	Size	30 \times 50	PO No.	
ROHS Report			REACH Report		

Items	Test Standard	AQL		Failed Qty	Failure Reason	Conclusion
		Ac	Re			
Out-looking Check	Normal outlooking, Clear marks, No noticeable damage, Size compliant to diagram	0	1	0	/	OK
Capacitance (C)	5440~8160 μ F	0	1	0	/	OK
Dissipation Factor (DF)	\leq 20 %	0	1	0	/	OK
Leakage Current(charge for 5 minutes)	\leq 8568 μ A	0	1	0	/	OK
Impedance	4.64 A	0	1	0	/	OK
Weldability	Lead well coated	0	1	0	/	OK
Leas tensile	Normal outlooking, Clear marks, No noticeable damage, Stable Features	0	1	0	/	OK
Welding Heat Resistance	No noticeable damage, Capacitance Fluctuation \leq 5%	0	1	0	/	OK
Stress Release	Safety Vent Open, no explosion nor burning	0	1	0	/	OK

Electrolytic Features Test

Data No.	Capacitance (μ F) (120HZ)	Dissipation (tan δ) % (120HZ)	Leakage Current (μ A) ((charge for 5 minutes))
1	6165	12.9	325
2	6158	12.6	316
3	6296	12.8	308
4	6184	12.5	328
5	6127	12.7	329
6	6149	12.4	321
7	6175	12.8	337
8	6137	12.3	305
9	6158	12.9	317
10	6193	12.7	309

Inspected by: 李晓庆

Approved ed by: 曾观红